

Giraud Tool Co., Inc.

TRI WAY Cartridge Case Trimmer

U.S. Patents 9,459,082 and 9,541,365

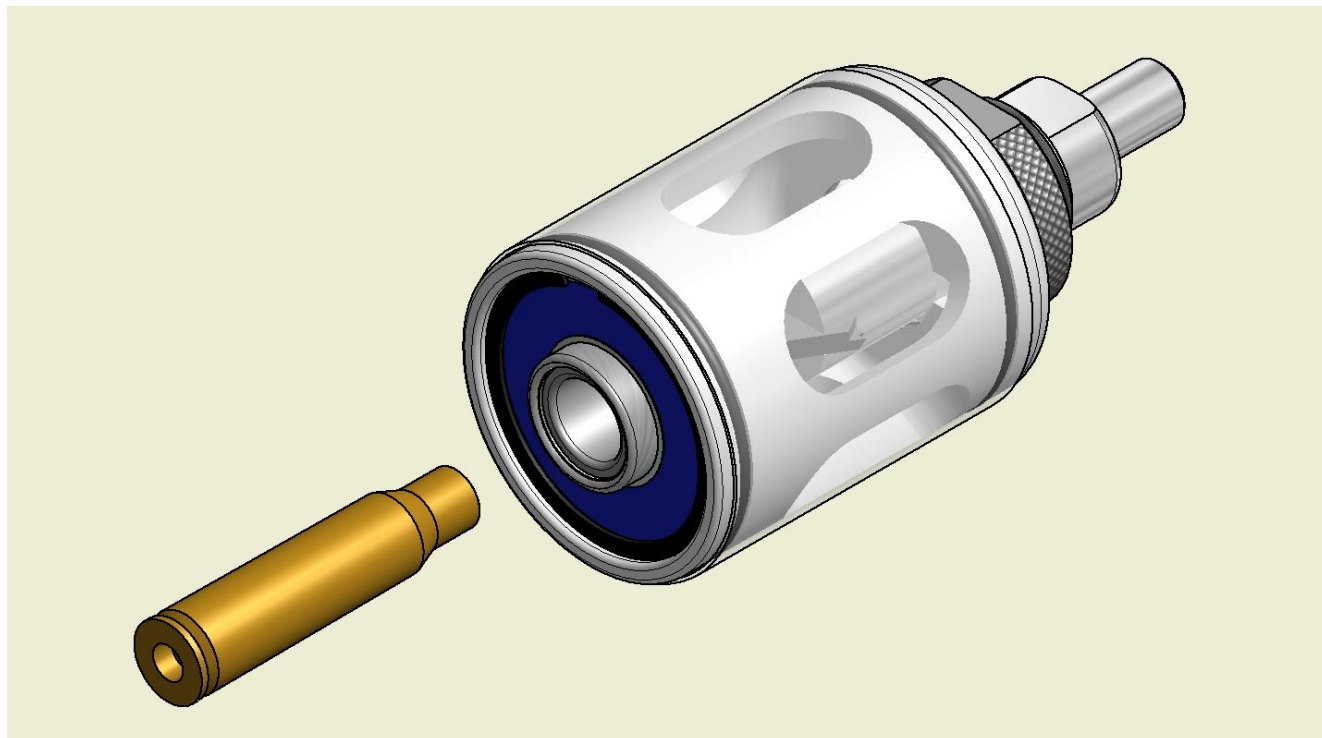

PLEASE READ AND FOLLOW THESE DIRECTIONS BEFORE ATTEMPTING TO USE THIS DEVICE.

Description

The Giraud Tri Way Cartridge Case Trimmer is designed for the shooter or reloader needing a dependable budget priced case trimmer for popular bottleneck rifle cartridge cases that trims and chamfers full length resized cases at the same time. This trimmer will provide the user with uniform trimming and chamfering of full length resized rifle cartridges in a single operation.

The trimmer comes complete and ready to use, set up in one caliber. Cartridge choices are limited to only high volume popular sizes. The cartridge case choices are:

.223 Remington and family (.17 Remington, .204 Ruger, .222 Remington)

.308 Winchester and family (.243 Winchester, .260 Remington, 7mm-08)

.30-06 Springfield and family (.25-06, .270 Winchester, .280 Remington)

.300 Blackout and family (.17 Rem Fireball, .221 Fireball)

7.62x39

300 Winchester Magnum and family (.264 Winchester, 7mm Remington Magnum)

Setting Up

The trimmer comes complete in one size. A sample full length resized case is included with the tool to identify the size it is setup for and to show the expected finished product, if used properly. Attempting to process fired or neck sized cases will most likely yield less than acceptable results. This tool is intended for use with full length resized cartridge cases.

To use the device, a rotating source of power is needed. Typically a corded or cordless drill would be used to drive the tool. Alternately, an electric, hydraulic, or pneumatic motor can be used to power the tool. If used with a surplus motor or other power source, the user is responsible to properly connect the tool to the power source. When looking at the end of the tool where cartridge cases are inserted, it should turn counterclockwise to properly cut. Turning in the opposite direction will damage the carbide blade irreparably.

The cutting action is done with a carbide blade specially ground to perform three different cutting actions simultaneously, trimming the overall length, chamfering the inside of the case mouth, and deburring the exterior of the case mouth. The carbide blade is the same part used in our other case trimmers and has three cutting surfaces. The blade may be rotated to another fresh surface as needed to extend the life of the tool. In normal use, these blades have a life expectancy of well over 25,000 cases trimmed, some users have reported over 100,000 cases trimmed on one surface of the three tipped blade.

The overall length of the finished cut can be adjusted by loosening the locking ring on the threaded shaft and rotating the threaded shaft in or out to shorten or lengthen the overall trimmed case length. One complete rotation of the shaft will change the overall trimmed length by approximately 0.072", one half turn will change the overall trimmed length by approximately 0.036", one quarter turn will change the overall trimmed length by approximately 0.018", one eighth turn will change the overall trimmed length by approximately 0.009".

The inside chamfer and outside deburr can be adjusted simultaneously also. If the inside chamfer is increased, the outside deburr will be decreased. The inside and outside cutting action cannot be independently adjusted due to the blade configuration cutting both inside and outside surfaces at the same time. To adjust, loosen the set screw holding the carbide blade to the shaft head and slide the blade along the mounting slot and retighten the set screw to hold the blade in place. It is suggested that the blade be held in place with a small screwdriver or tool while the blade is being loosened or tightened to prevent unintentional movement during the adjustment process. Place the blade of the screwdriver only on the notched surface of the blade, **not** in the V-shaped cutting surfaces.

THE CARBIDE BLADE SHOULD BE POSITIONED SO THE NOTCHED SURFACE SHOULD BE FACING THE SAME SIDE AS THE LOCKING SET SCREW FOR PROPER CUTTING.

Operation

This tool indexes cartridge cases off the bottleneck shoulder and will trim each case inserted into it to a repeatable length from the shoulder forward to the case mouth. If you experience variations in overall case length using this tool, it is because the headspace dimension of the resized cases is not consistent from case to case. Differences in cartridge case brand, number of loadings, type and amount of case lubricant used during resizing, type of reloading dies used, and method used to resize the case will have a great effect on the consistency of the finished product. The more consistent the resizing process is, the more consistent the finished trim length will be. No trimmer indexing off the shoulder will correct poor resizing technique.

If you notice the chamfers on the case mouth are uneven, it may be due to the resizing die moving the case neck out of concentricity with the case body. This can occur if the decapping stem in the resizing die is bent or located off center inside the die, or if bushing type dies are used improperly.

With the trimmer mounted in a powered hand drill, drill press chuck, or alternate power supply, the entire trimmer will rotate when the power is applied. Care should be taken to not grasp, rub, touch or otherwise come into contact with the rotating surfaces to prevent injury. When properly used for its intended purpose, the user should never need to come in contact with the rotating device. Only the cartridge case held by the user should ever touch the rotating trimmer.

As a precaution, users should not wear excessively loose long sleeve clothing, loose long hair, dangling jewelry (necklaces, lanyards, etc.), bulky loose fitting gloves, or personal electronic devices (headphone or earbug cords) while using any form of rotating equipment. Personal injury may occur if any or all of these items become entangled with the rotating machinery.

A clear plastic cover is included with the tool to contain the chips generated from the cutting action. This cover prevents trimming debris from being thrown into the face of the user and around the work area. Keep this cover in place whenever the trimmer is rotating. It may be removed from the tool by TWISTING AND SLIDING down off the body of the tool to empty debris from the containment area, clean the tool, and expose the cutting blade for adjustment. The cover is retained on the tool body by friction created between the rubber O-rings and the inside surface of the cover. Make sure when installed, the cover must reach over the windows of the trimmer body centered between the upper and lower O-rings. Some units may not have both O-rings installed, the number of O-rings varies according to the fit of the extruded plastic cover to the machined aluminum trimmer body.

The preferred method of trimming using this tool is to orient the tool such that the case is pressed into the tool using a straight upward or downward motion. This allows brass chips and shavings generated by the trimming process to fall away from the insert supporting the cartridge case. If the tool is used horizontally or angled less than vertical, there is the possibility of chips and shavings entering the insert supporting the cartridge case between the removal of one case and insertion of the next. If this occurs, the next case may trim improperly or unevenly due to the debris preventing the case from fully seating or being supported unevenly. If this occurs, a plain cotton swab can be used to wipe the chamber insert clean.

To trim a cartridge case, firmly grasp a case by the lower portion of the case and gently insert it into the rotating tool. As the blade starts to cut the case mouth, the case will vibrate and you may hear the cutting action. Continue to slowly push the case into the tool until there is no more forward motion possible and the vibration and sound have noticeably decreased. At this time, continue to push the case into the tool and twist the case 180 degrees while still in contact with the cutting blade. This will even out most uneven chamfers. Pushing the cartridge case into the trimmer more aggressively may cause the case to catch on the cutting blade and spin from your grasp. If this happens, remove the case and repeat the process, inserting the case SLOWER with a firm grip. After a few cases, you will notice the proper technique and speed.

Clean the trimmer body of chips after every use by holding the tool over a suitable trash receptacle and sliding the cover off the trimmer body. Shake the tool to allow debris to fall from the trimmer body into the trash receptacle. Any remaining debris can be brushed from the trimmer body with a small paint brush. Do not blow with high pressure compressed air or damage may result in contaminating the ball bearing or forcing chips into your face and eyes.

If you have any problems with this tool or questions about operation, call or email and we will be glad to help you.

Doug Giraud
Giraud Tool Company, Inc.
3803 Dawn Lane
Richmond, Texas 77406
713-907-2695 cell
281-238-0844 orders